

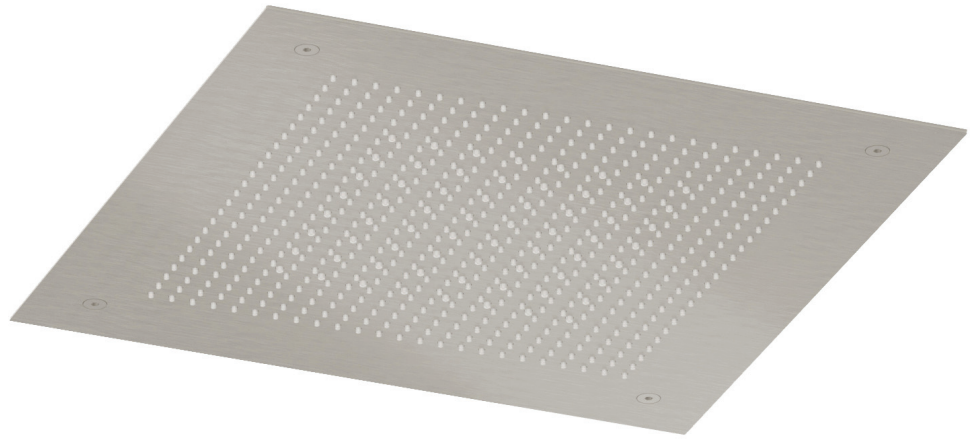

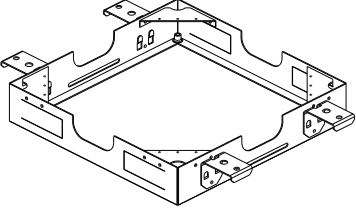

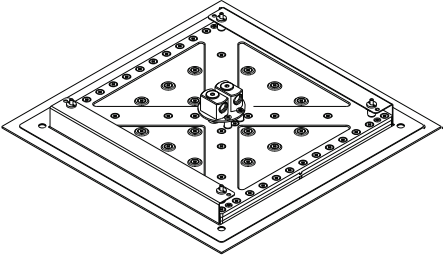

**RE051**

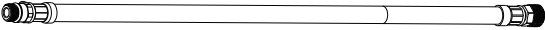

# Pack

Contenuto confezione  
 Package contents  
 Contenu de l'emballage  
 Packungsinhalt  
 Contenido del paquete

	<p>RE051</p> <p>X1</p>
	<p>X1</p>
	<p>X4</p>
	<p>X2</p>
	<p>X2</p>
	<p>X2</p>
	<p>X4</p>
	<p>X1</p>

- | IT | Istruzioni di montaggio
- | GB | Mounting instructions
- | FR | Instructions de montage
- | DE | Montageanweisungen
- | ES | Instrucciones de montaje

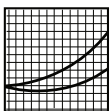
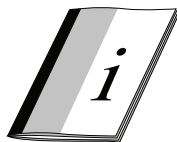

- | IT | Diagramma di flusso
- | GB | Flow rate
- | FR | Le débit
- | DE | Flussdiagramm
- | ES | Diagrama de caudal

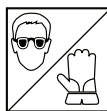

- | IT | Indossare protezioni
- | GB | Wear protection
- | FR | Porter une protection
- | DE | Schütze anziehen
- | ES | Usar protección



- | IT | Caratteristiche idrauliche
- | GB | Plumbing specifications
- | FR | Caractéristiques hydaruliques
- | DE | Hydraulische Eigenschaften
- | ES | Características hidráulicas



- | IT | Pressione d'uso
- | GB | Operating pressure
- | FR | Pression d'utilisation
- | DE | Betriebsdruck
- | ES | Présion de uso



- | IT | Temperatura dell'acqua
- | GB | Water temperature
- | FR | Temperature de l'eau
- | DE | Wassertemperatur
- | ES | Temperatura del agua

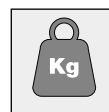

- | IT | Peso kg
- | GB | Weight kg
- | FR | Poids kg
- | DE | Gewicht kg
- | ES | Peso kg

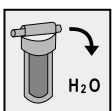

- | IT | Si consiglia l'installazione di un filtro a monte dell'impianto
- | GB | We recommend installing a filter upstream of the plant
- | FR | Nous recommandons l'installation d'un filtre en amont du système
- | DE | Wir empfehlen den Einbau eines Filters vor dem externen Wasseranschluss
- | ES | Se recomienda el montaje de un filtro antes de la instalación

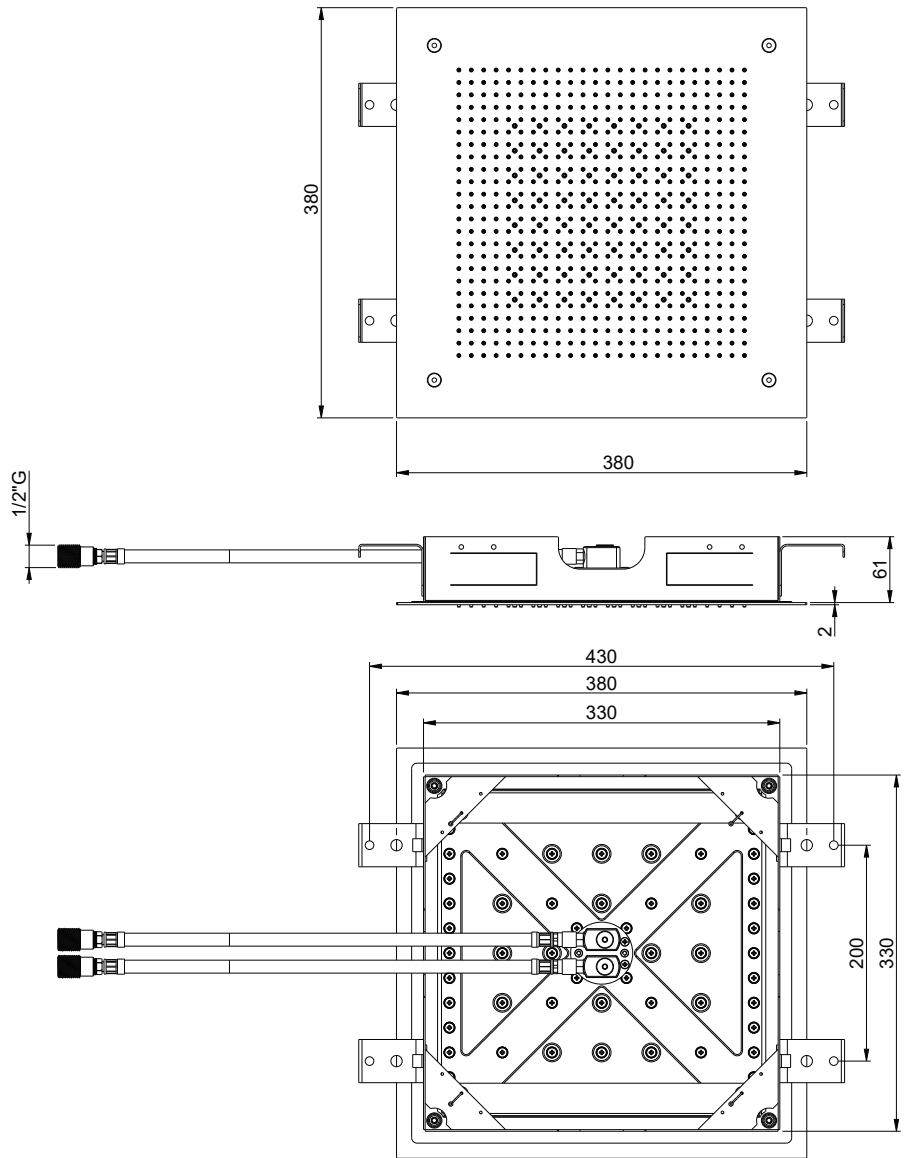
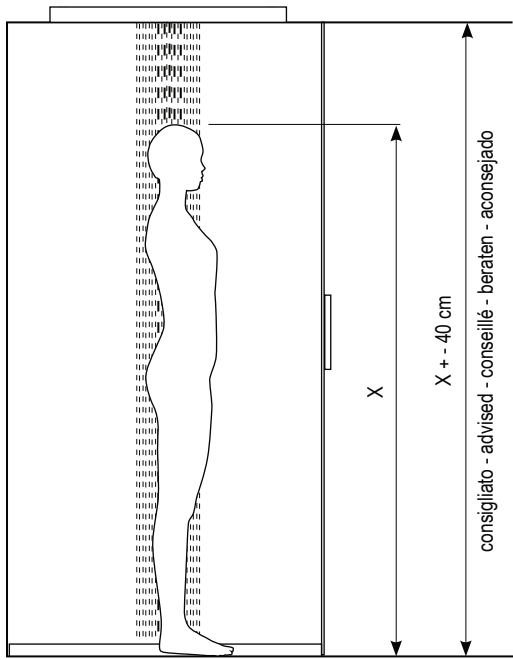

- |  |   |                          |
|--|---|--------------------------|
|  | ◆ | IT   Portata l/m Softjet |
|  |   | GB   l/m Softjet flow    |
|  |   | FR   Débit l/m Softjet   |
|  |   | DE   l/m Softjet fluss   |
|  |   | ES   Caudal l/m Softjet  |
|  | ▲ | IT   Portata l/m Rainjet |
|  |   | GB   l/m Rainjet flow    |
|  |   | FR   Débit l/m Rainjet   |
|  |   | DE   l/m Rainjet fluss   |
|  |   | ES   Caudal l/m Rainjet  |

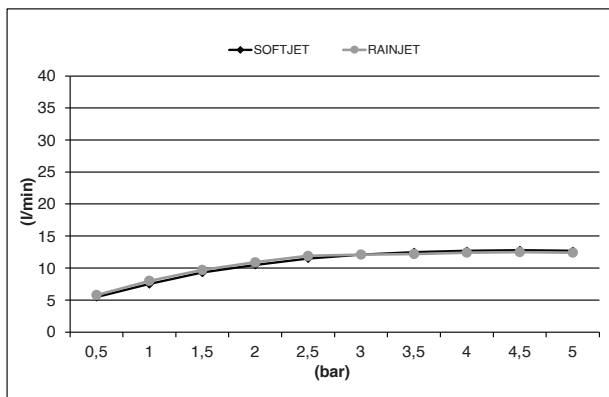

	MIN 7L/min SOFTJET MIN 7L/min RAINJET		MAX 70° C BEST 38/40° C
	MIN 1 Bar MAX 5 Bar BEST 3 Bar		ATTENTION ! *
			6,5 Kg

- | IT | \* Si consiglia l'installazione di un filtro a monte dell'impianto
- | GB | \* We recommend installing a filter upstream of the plant
- | FR | \* Nous recommandons l'installation d'un filtre en amont du système
- | DE | \* Wir empfehlen den Einbau eines Filters vor dem externen Wasseranschluss
- | ES | \* Se recomienda el montaje de un filtro antes de la instalación

### FLOW RATE CHART (Litres/Minute)

	Dynamic Pressure (bar) / Water flow (Litres/Minute)									
Bar	0,5	1	1,5	2	2,5	3	3,5	4	4,5	5
<b>SOFTJET</b>	5,5	7,5	9,3	10,5	11,5	12,1	12,5	12,7	12,8	12,7
<b>RAINJET</b>	5,8	8	9,7	10,9	11,9	12,1	12,2	12,4	12,5	12,4

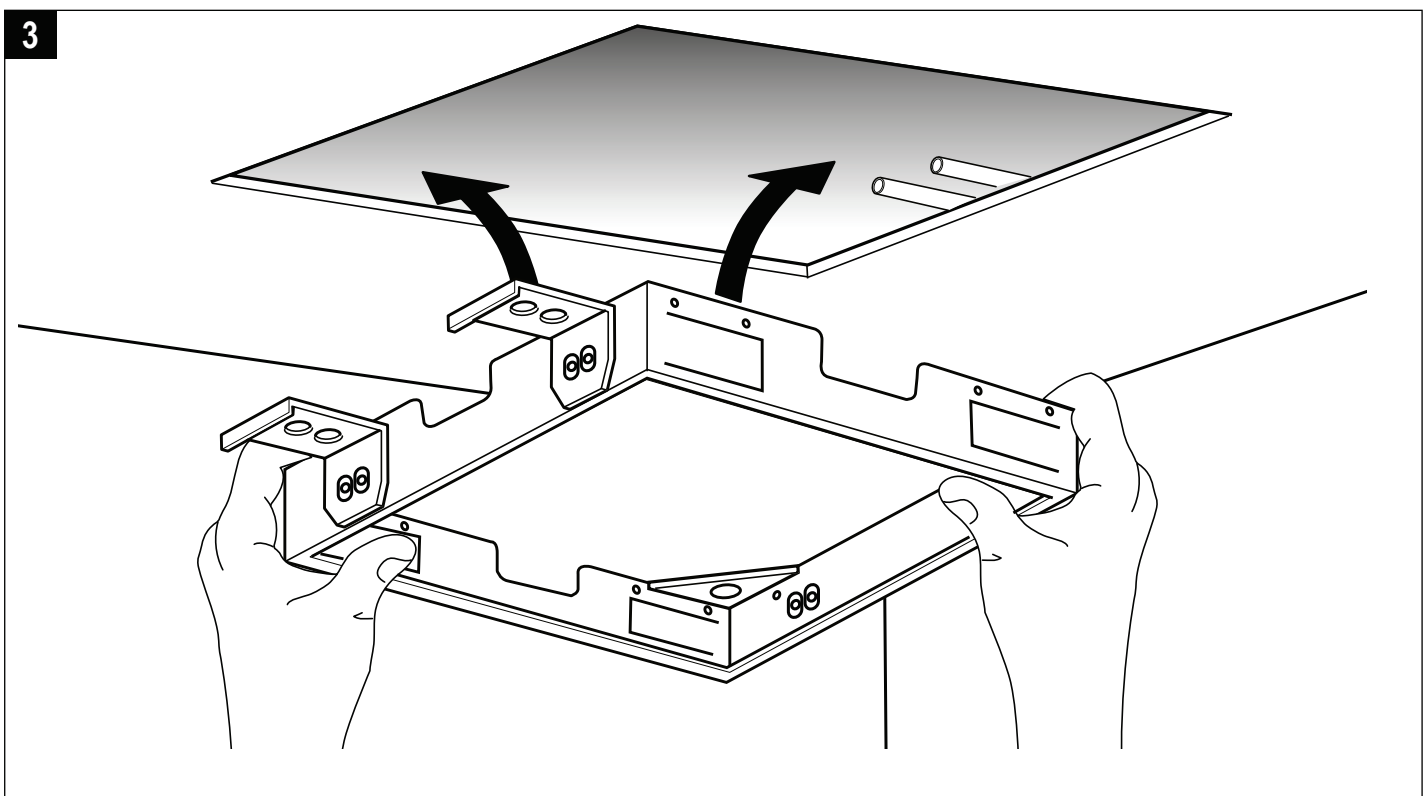
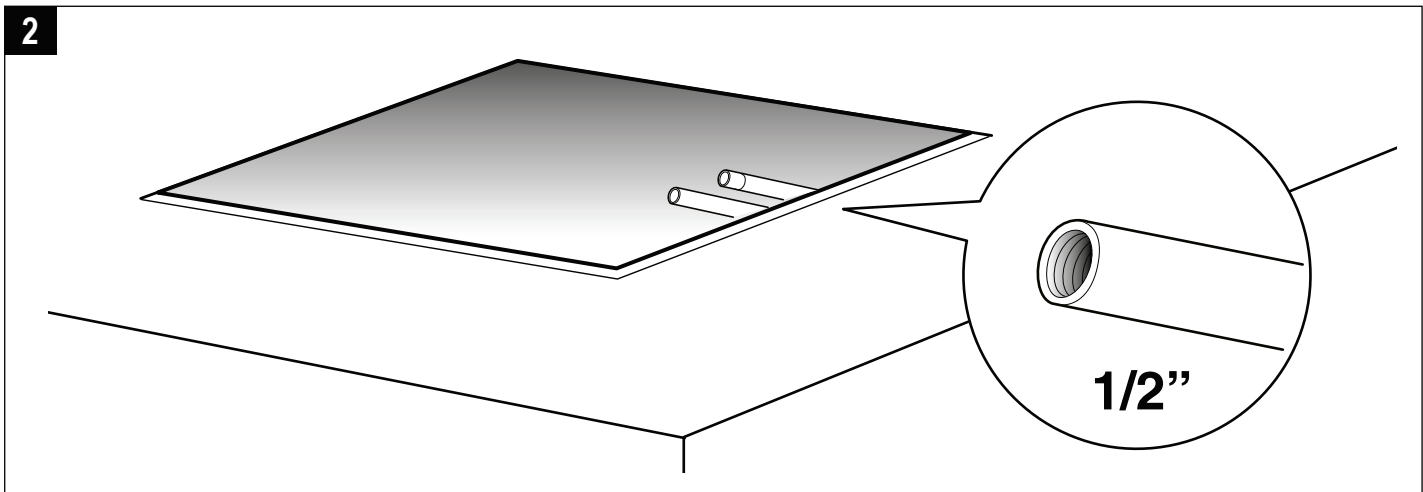
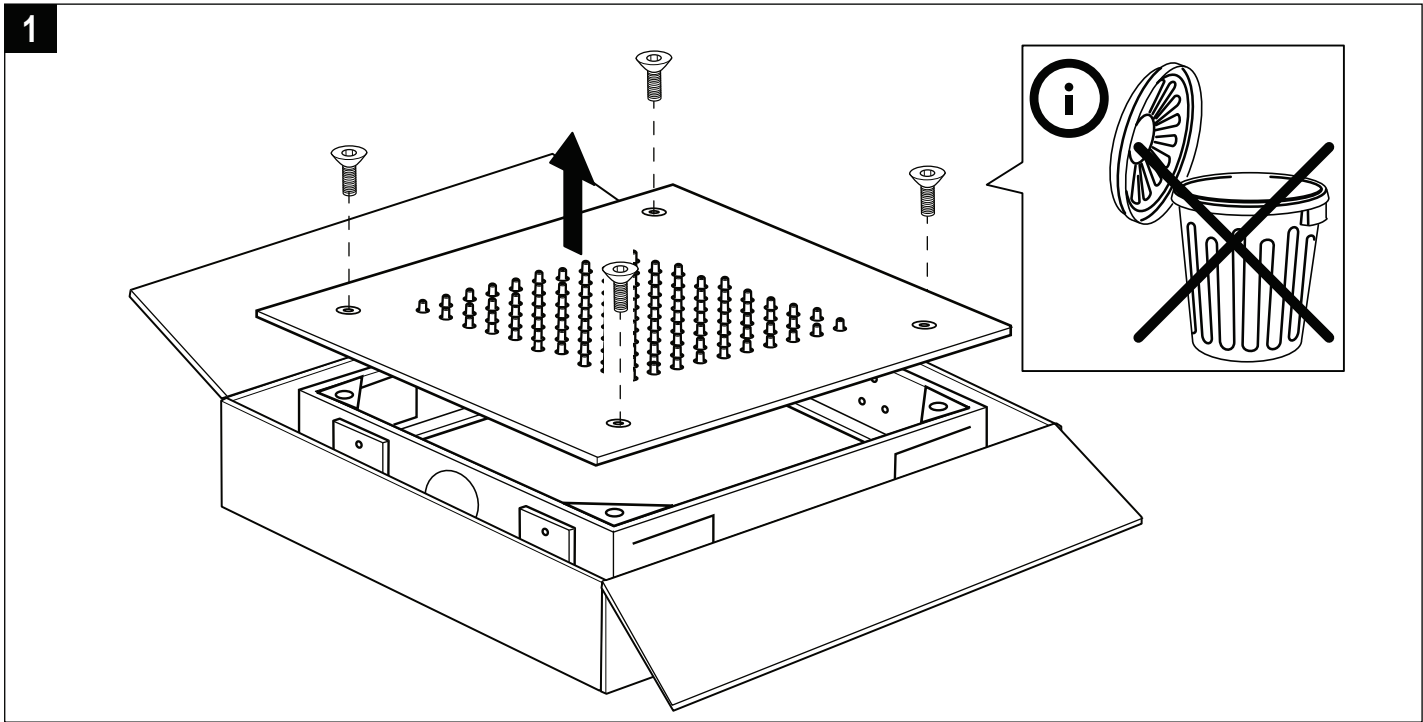

4

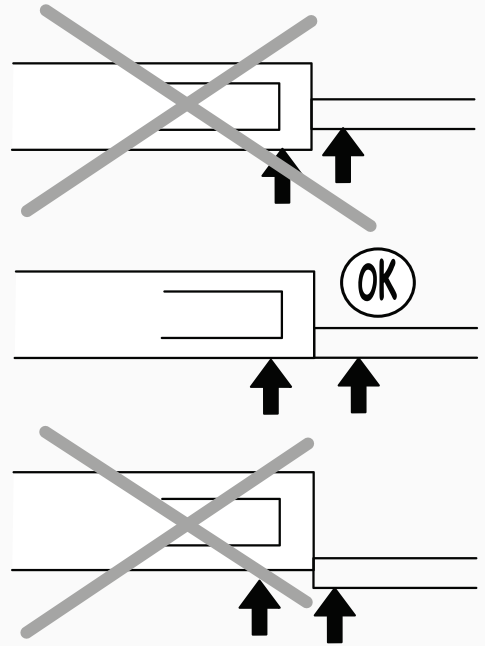
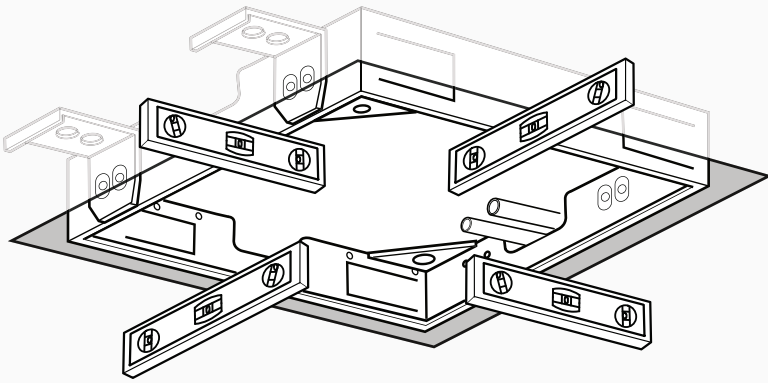

5

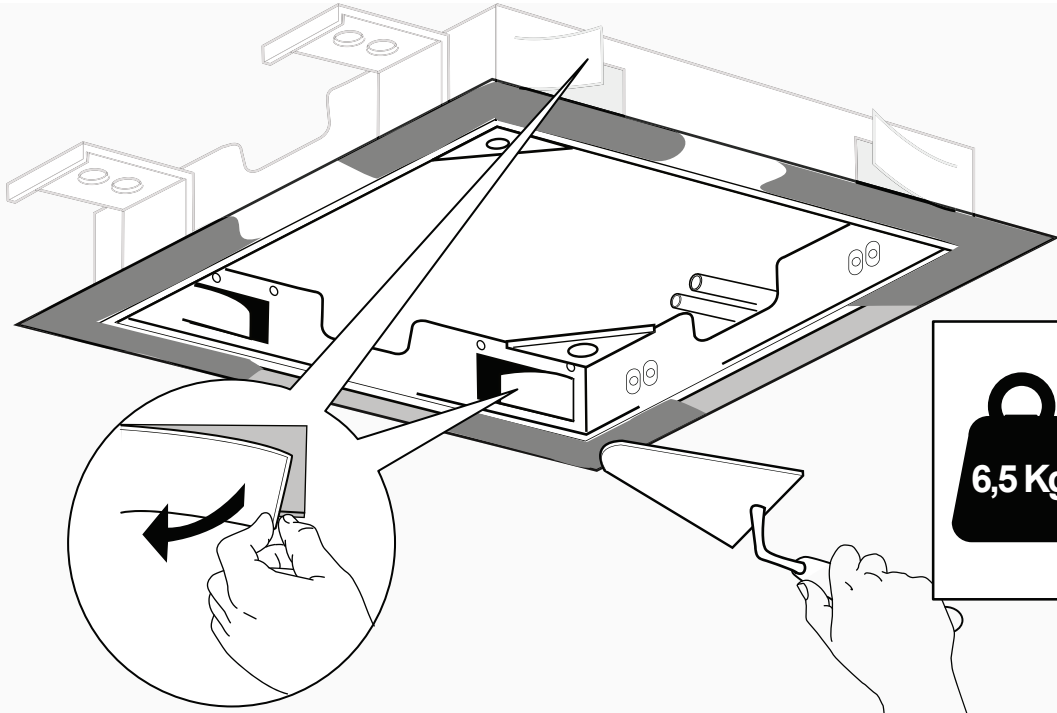

6

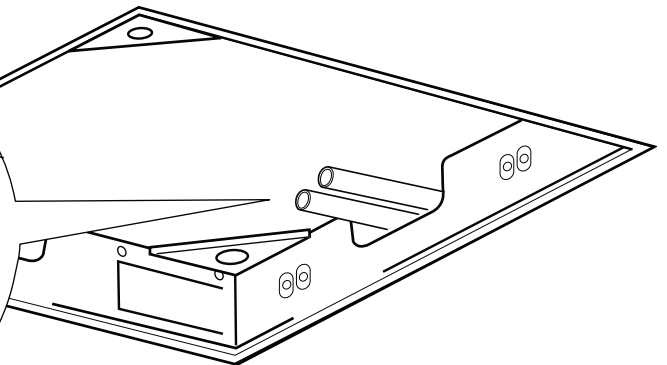
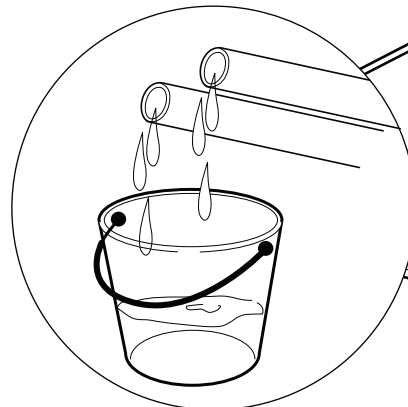
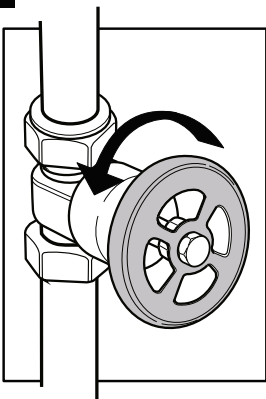

7

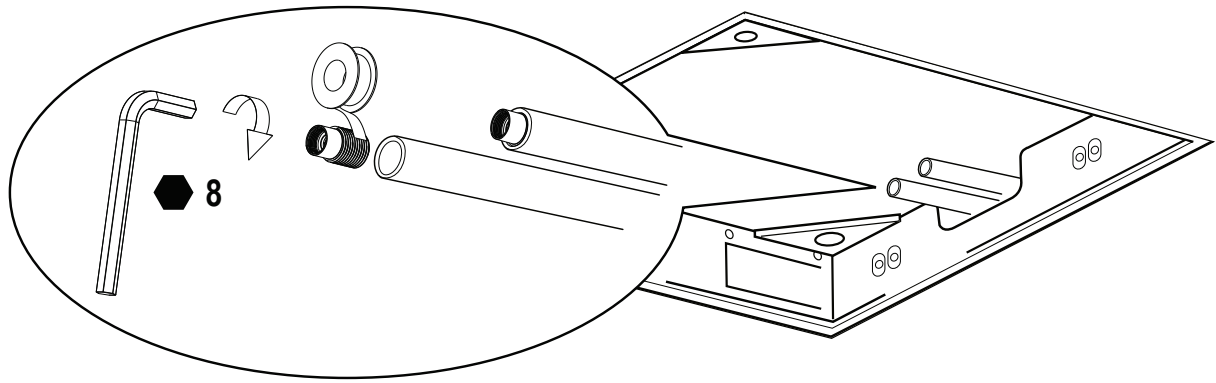

8

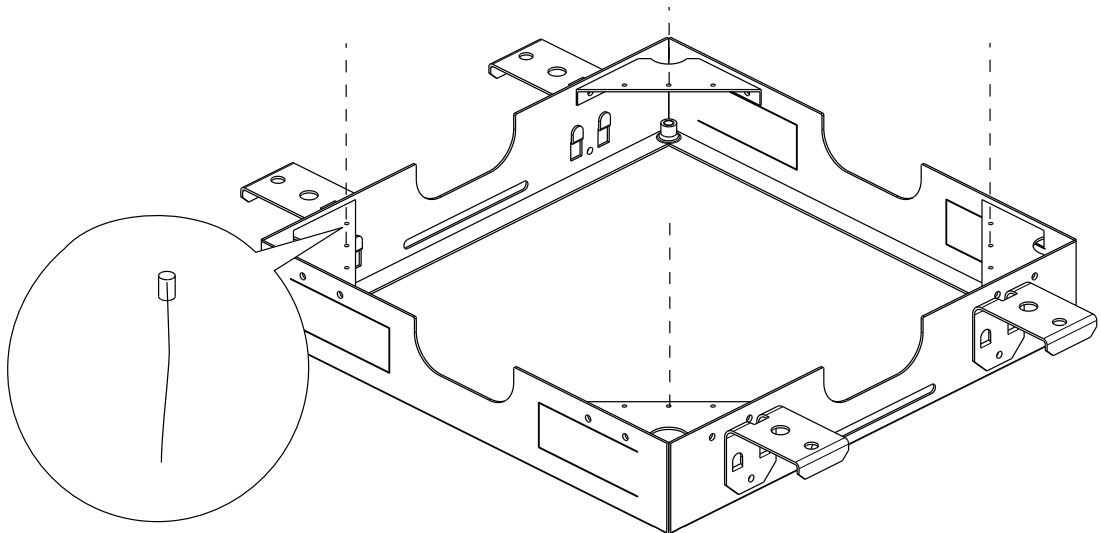

9

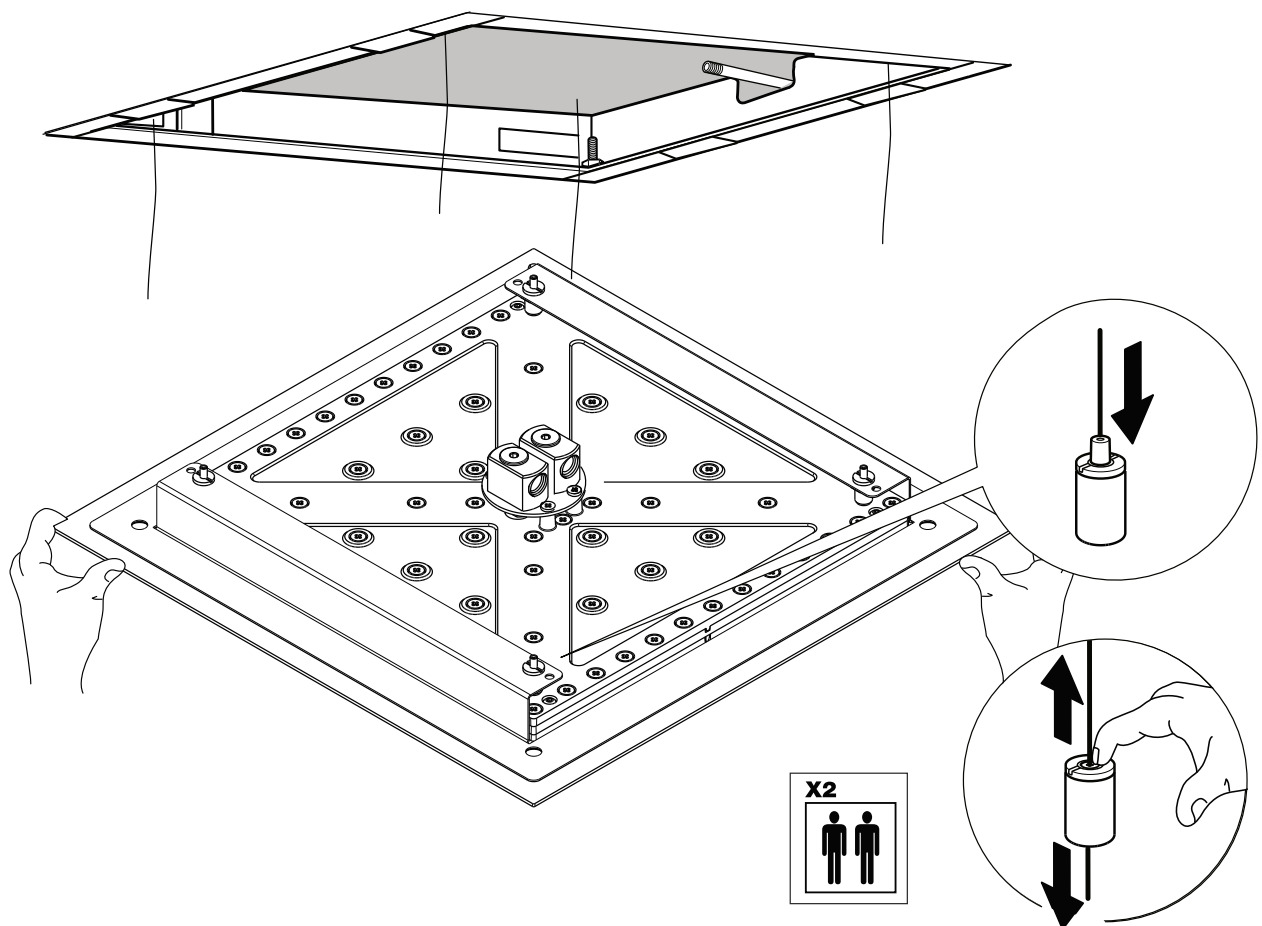

10

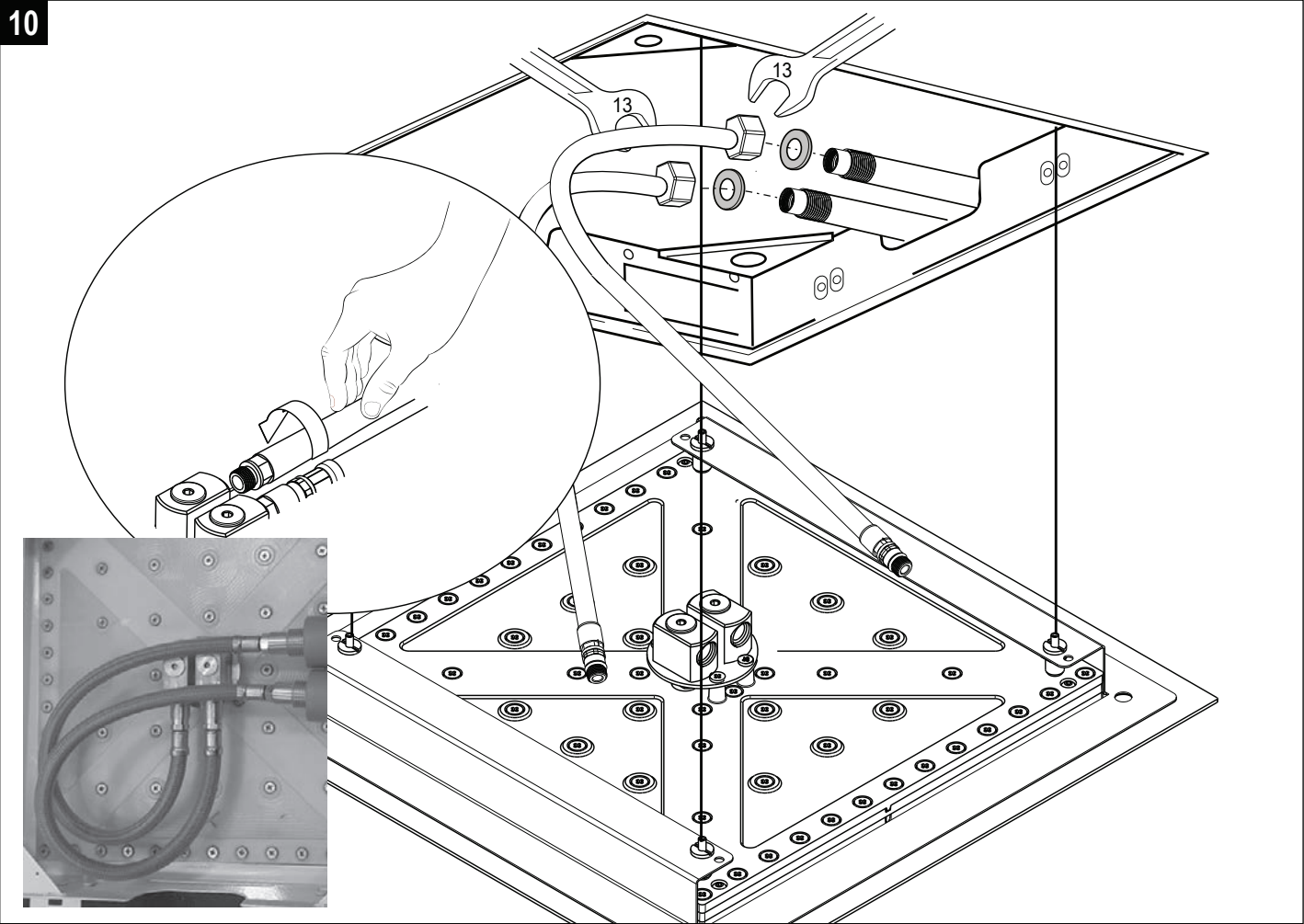

11

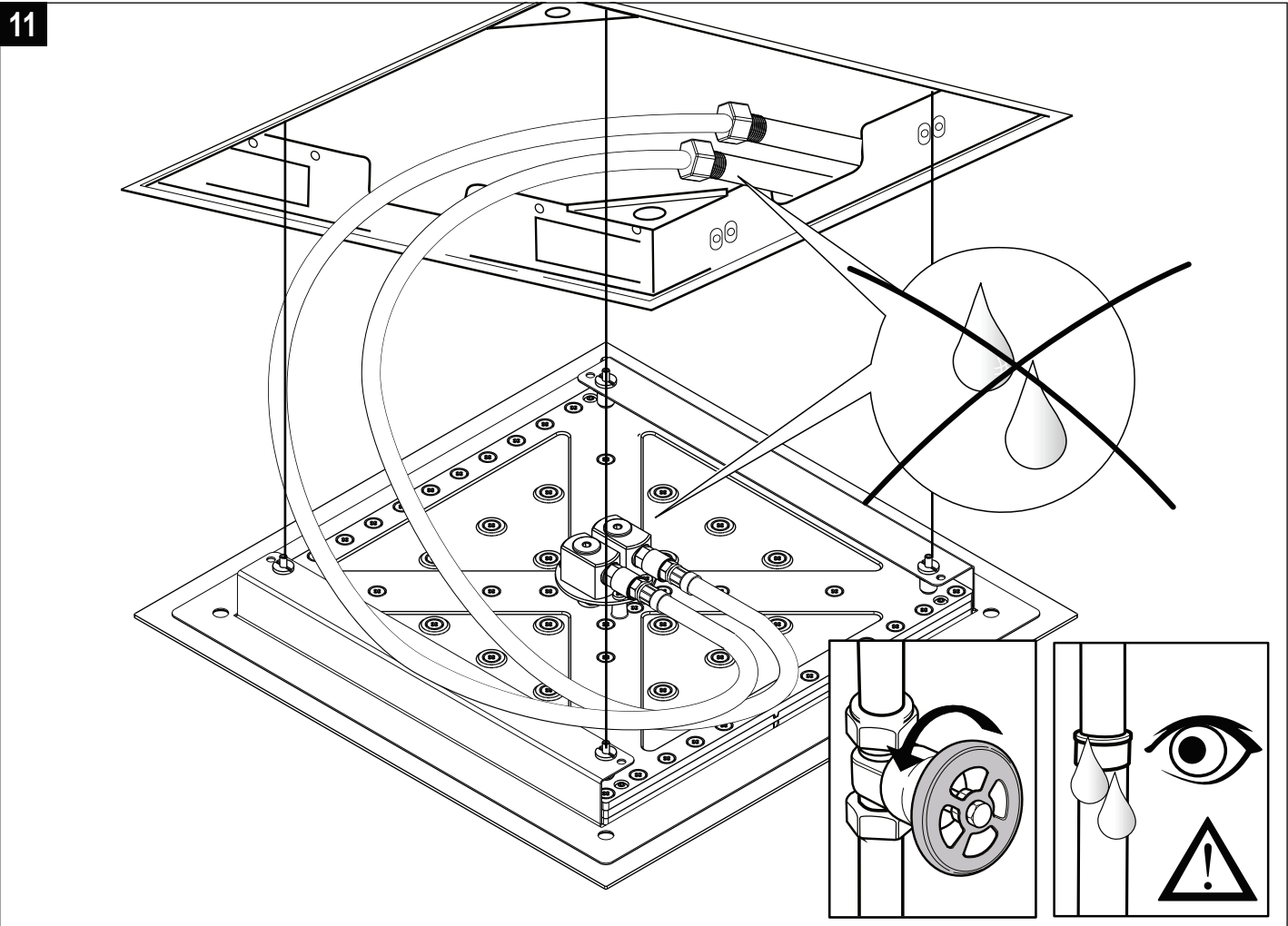

12

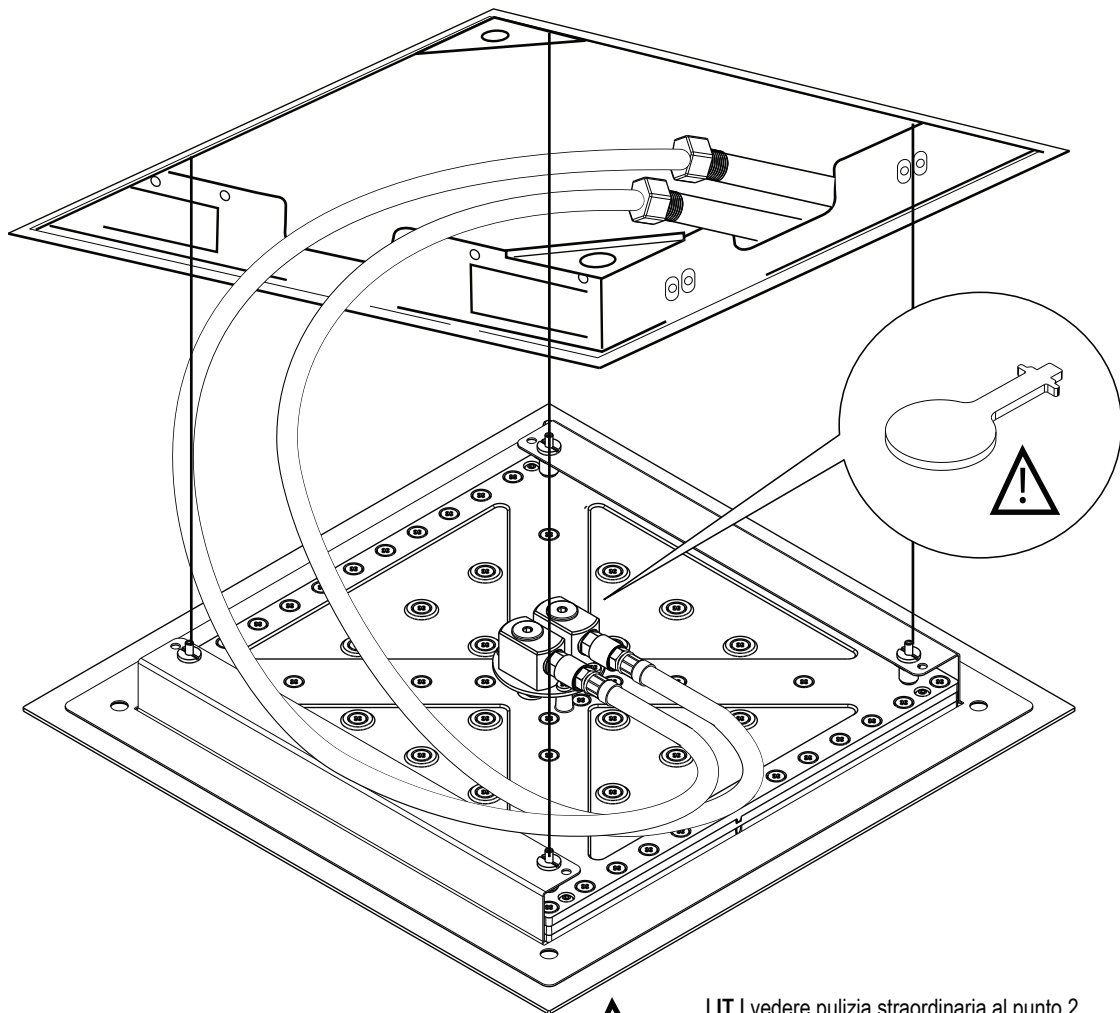

IT | vedere pulizia straordinaria al punto 2  
EN | see extraordinary cleaning - point 2  
DE | sehen Sie bitte außerordentliche Reinigung - Punkt 2  
FR | voir nettoyage extraordinaire - point 2  
ES | ver limpieza extraordinaria - punto 2

13

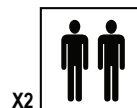
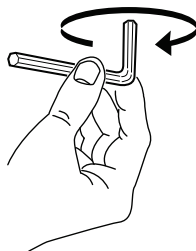
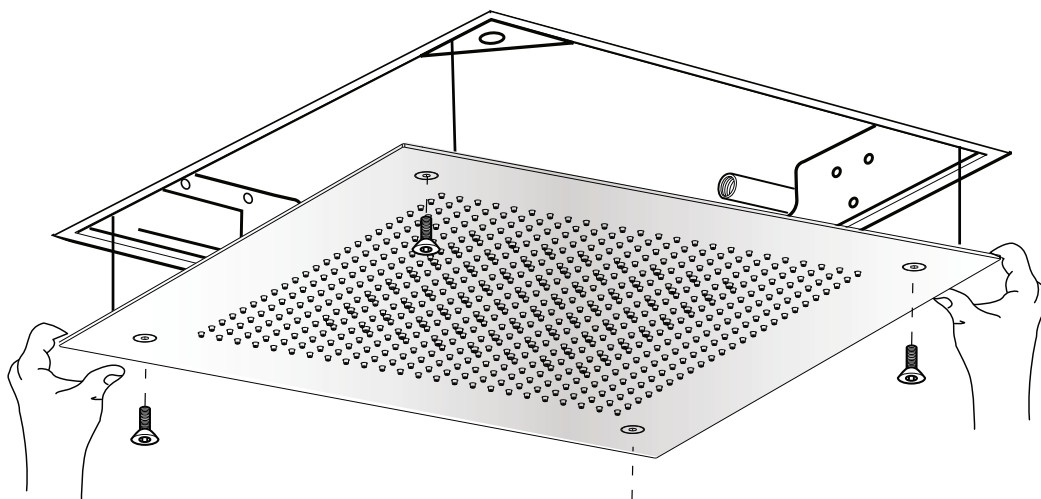



# Cleaning

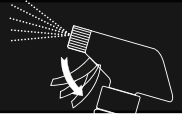

Suggerimenti per la pulizia ordinaria  
Ordinary Cleaning Tips  
Conseils de nettoyage ordinaire  
Gewöhnliche Reinigung Tipps  
Consejos de limpieza ordinaria

1

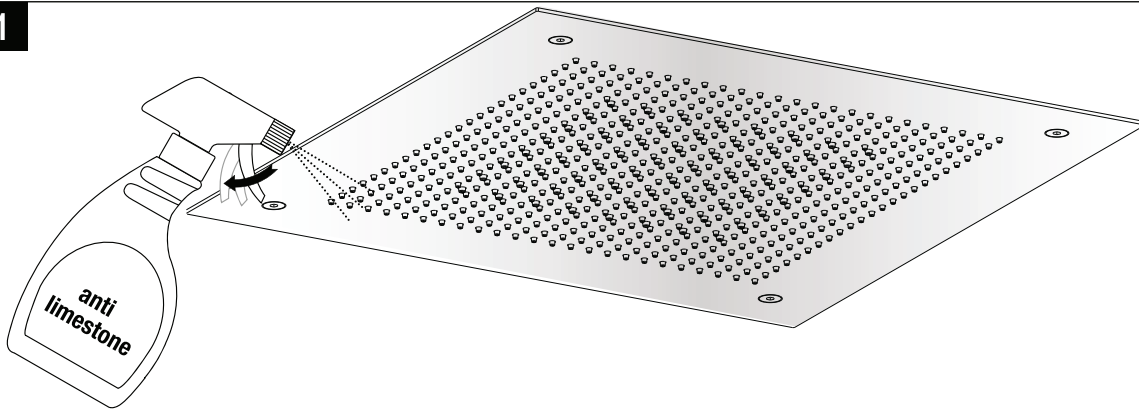

2

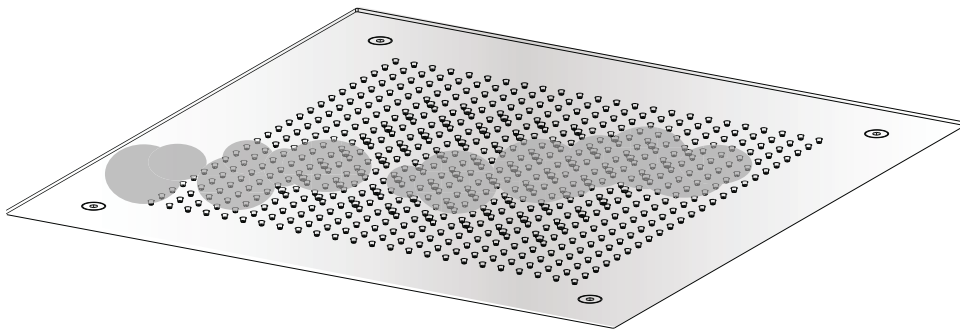

10 min

3

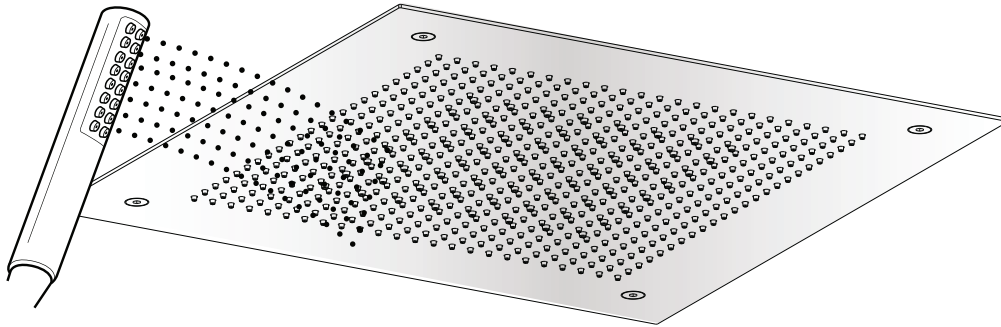

4

Calcare  
Limestone  
Calcaire  
Kalkstein  
Piedra caliza

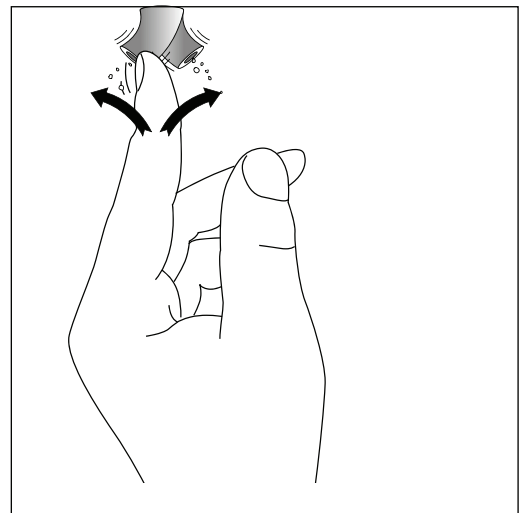
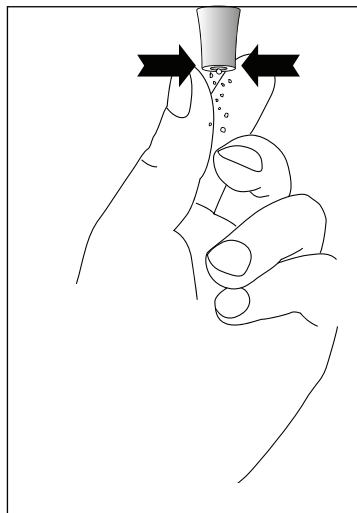
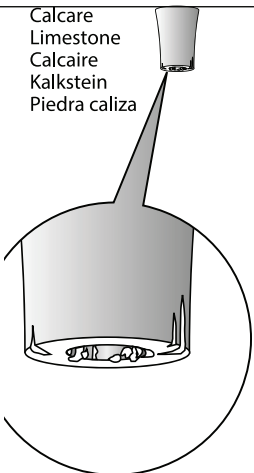

# Cleaning

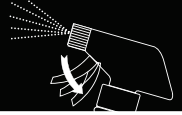

Suggerimenti per la pulizia straordinaria  
Extraordinary Cleaning Tips  
Conseils de nettoyage extraordinaire  
Außerordentliche Reinigung Tipps  
Consejos de limpieza extraordinaria

1

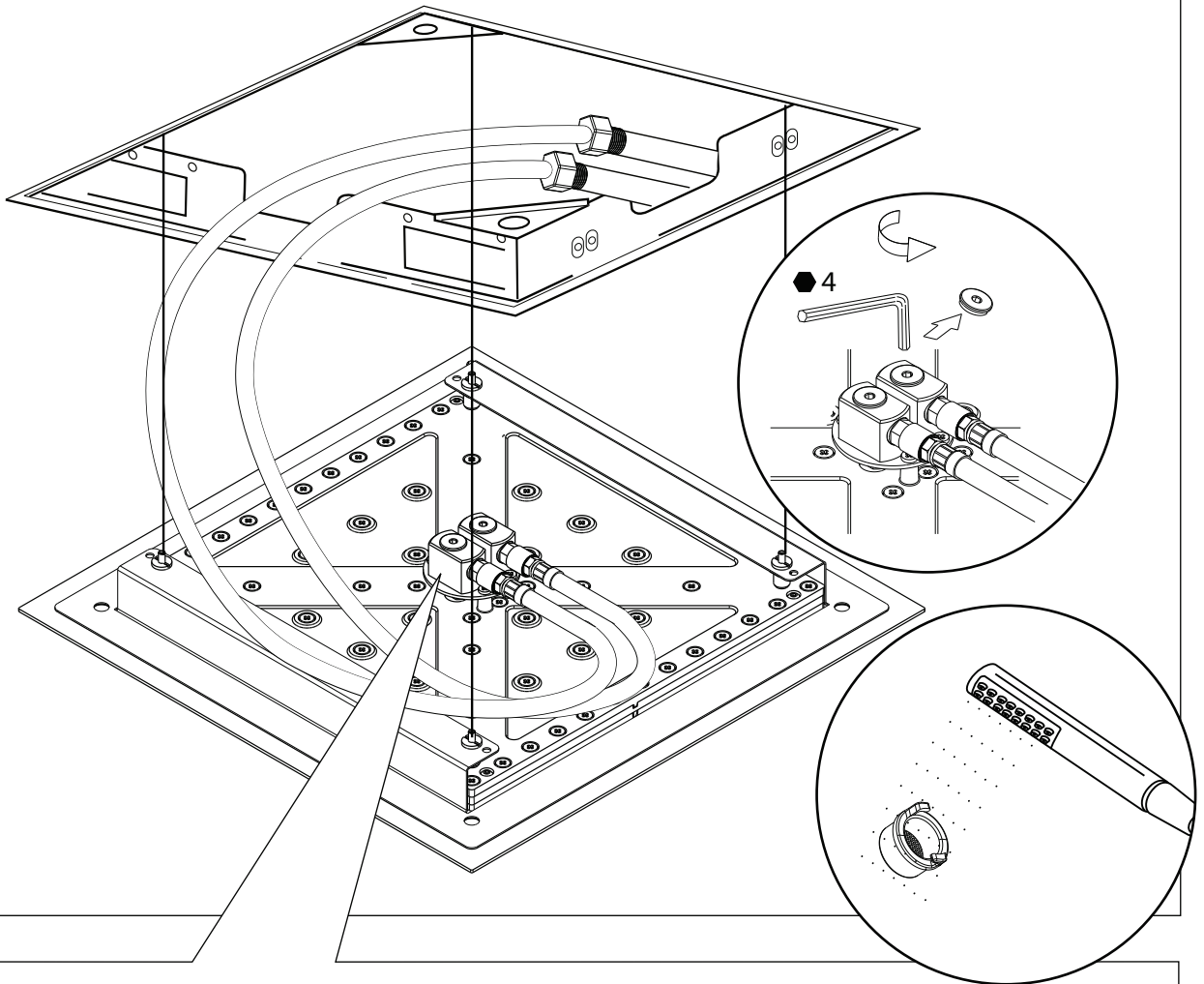



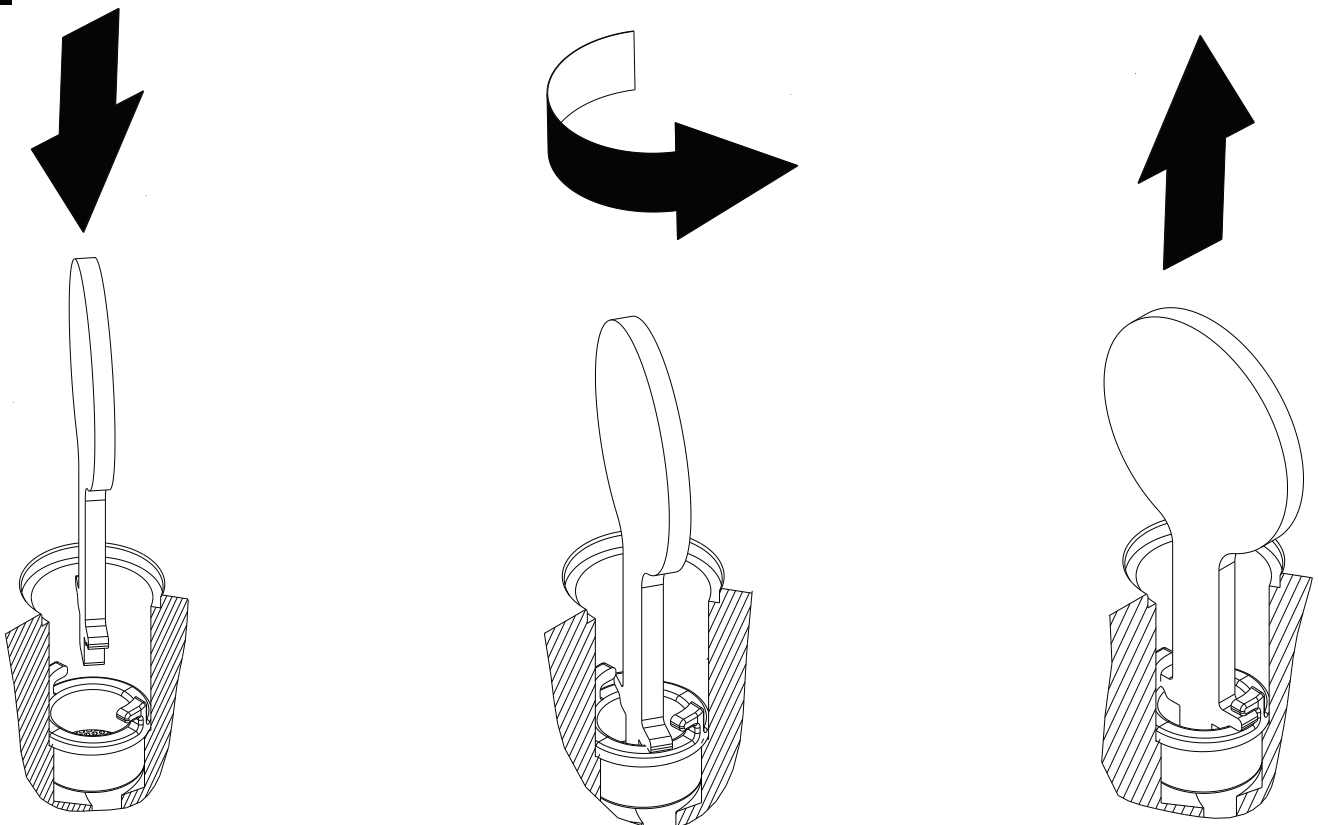







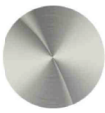









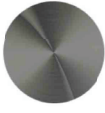









2





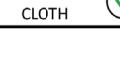

# CLEANING - PULIZIA - NETTOYAGE - REINIGUNG - LIMPIEZA

Finish		✓			✗	
<b>BS Brushed Steel</b> 316 stainless steel		 WATER ✓	 LIQUID SOAP ✓	 SMOOTH CLOTH ✓	 ACID/ABRASIVE DETERGENT ✗	 ABRASIVE SPONGE ✗
		 WATER ✓	 LIQUID SOAP ✓	 SMOOTH CLOTH ✓	 ACID/ABRASIVE DETERGENT ✗	 ABRASIVE SPONGE ✗
<b>BB Brushed Black</b> PVD finish on stainless steel		 WATER ✓	 LIQUID SOAP ✓	 SMOOTH CLOTH ✓	 ACID/ABRASIVE DETERGENT ✗	 ABRASIVE SPONGE ✗
		 WATER ✓	 LIQUID SOAP ✓	 SMOOTH CLOTH ✓	 ACID/ABRASIVE DETERGENT ✗	 ABRASIVE SPONGE ✗
<b>BC Brushed Copper</b> PVD finish on stainless steel		 WATER ✓	 LIQUID SOAP ✓	 SMOOTH CLOTH ✓	 ACID/ABRASIVE DETERGENT ✗	 ABRASIVE SPONGE ✗
		 WATER ✓	 LIQUID SOAP ✓	 SMOOTH CLOTH ✓	 ACID/ABRASIVE DETERGENT ✗	 ABRASIVE SPONGE ✗

AMPHORA  
WATER SOURCE

Via dello Statuario 15  
 I-55045 Pietrasanta - Italy  
 info@amphoradesign.it  
 Rocco Ponsi  
 +39 345 3916748  
 rocco.ponsi@amphoradesign.it